

# MAGIS

Substance by Naoto Fukasawa

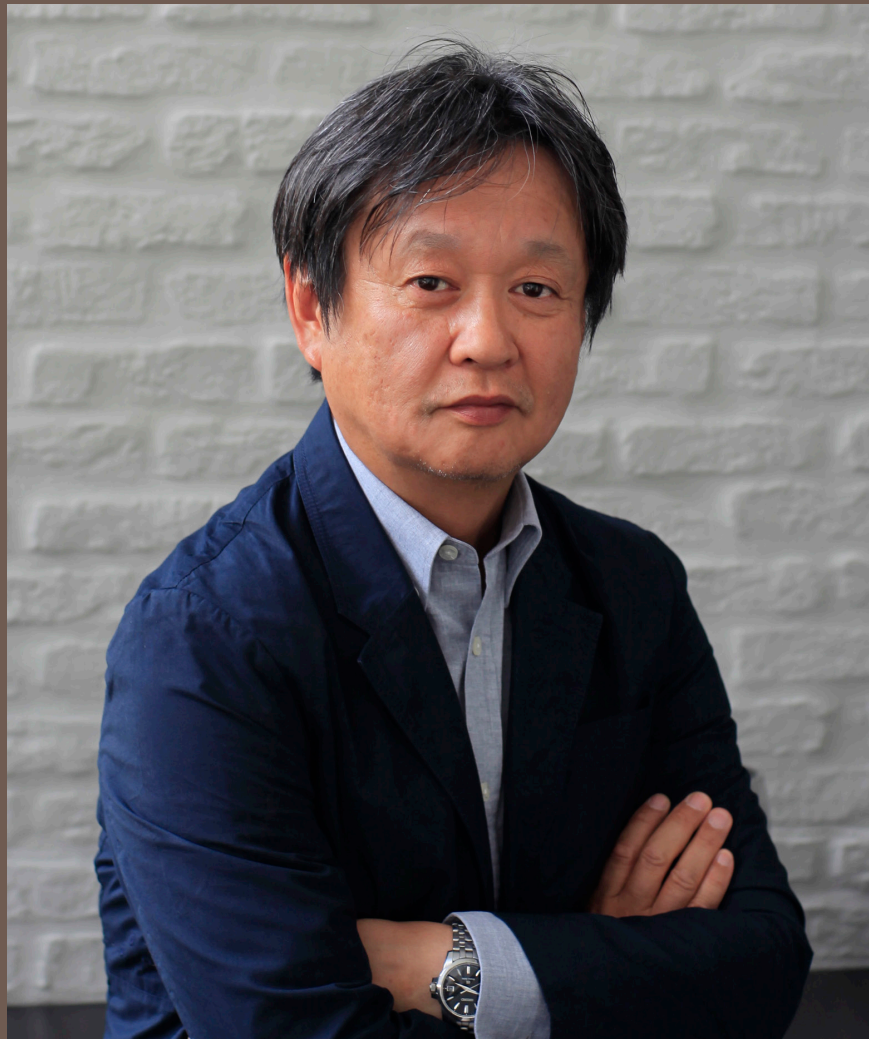

# Naoto Fukasawa



## Profile:

With his designs devoted to simplicity and sublime beauty, Fukasawa has designed for a wide range of leading brands worldwide in Italy, Germany, America, Switzerland, Spain, China, Korea, Thailand, Taiwan, Singapore, France, Portugal, Sweden and Finland, as well as consulting and working with Japanese major corporations. His designs span a wide variety of fields, from precision electronic equipment to furniture and interior settings. He has received numerous national and international design awards. His wall-mounted CD player for MUJI, humidifier for  $\pm 0$  and the mobile phones INFOBAR and neon for au/KDDI are all part of New York's Museum of Modern Art's (MoMA) permanent collection. In 2007, he was accorded the title of Honorable Royal Designer for Industry (Royal Society of Arts), UK. MUJI's wall-mounted CD player is also part of the Victoria and Albert Museum's permanent collec-

tion, while his HIROSHIMA armchair for MARUNI is part of Designmuseum Danmark's permanent collection. Fukasawa is one of the directors of 21\_21 DESIGN SIGHT. He also sits on the design advisory board of MUJI, and is the art director of MARUNI. In 2017, he became a member of the judging committee for the LOEWE Craft Prize. He is a professor in the Integrated Design department at Tama Art University. In 2006, he established "Super Normal" with Jasper Morrison. He has been acted as the 5th curator of The Japan Folk Crafts Museum since 2012.

Fukasawa has co-authored The Outline – The Unseen Outline of Things (Hachette Fujingaho) with photographer Tamotsu Fujii and released NAOTO FUKASAWA (Phaidon Press). In Spring 2018, He released his Second book with Phaidon press, Naoto Fukasawa Embodiment.



# Design and

“I wanted to try working on a chair that has a simple cross junction of two U-shaped legs. Then I wanted to put a simple shell on top. Combining the bending details of the legs and the bottom curve of the shell of this chair creates such a friendly feeling. It is common to have a chair with a shell and legs that extend off the shell whereas this bending detail on Substance gives a fresh quality. I believe we have successfully produced a sustainable chair”.

Naoto Fukasawa



# Engineering



Substance is the combination of two U-shaped legs in



three different materials and a simple polypropylene shell.



# Information



## Product

### FRAME IN ASH PLYWOOD

Chair and armchair with frame in ash plywood, natural or painted. Seat in polypropylene. Complete with felt pads.

### FRAME IN ANODISED ALUMINIUM

Chair and armchair with frame in anodised aluminium tube. Seat in polypropylene. Complete with felt pads.

### FRAME IN STEEL TUBE

Armchair and stacking chair with or without arms with frame in steel tube chromed or painted in polyester powder. Seat in polypropylene. Complete with felt pads.





Substance stacking chair w/ frame in steel tube



Frame in steel tube /  
Painted white or black

Seat in polypropylene /  
White, Black or Grey beige

Substance stacking chair w/ frame in steel tube and arms



Frame in steel tube /  
Painted white or black

Seat in polypropylene /  
White, Black or Grey beige

Substance armchair w/ frame in steel tube



Frame in steel tube /  
Painted white or black

Seat in polypropylene /  
Colours

Frame in steel tube /

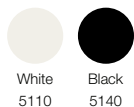

White 5110  
Black 5140

Polypropylene /



White 1735 C  
Black 1768 C  
Grey beige 1452 C  
Mustard 1015 C

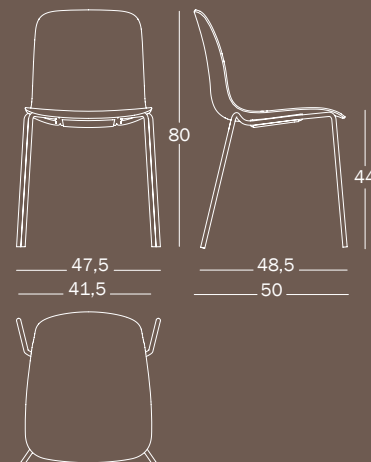
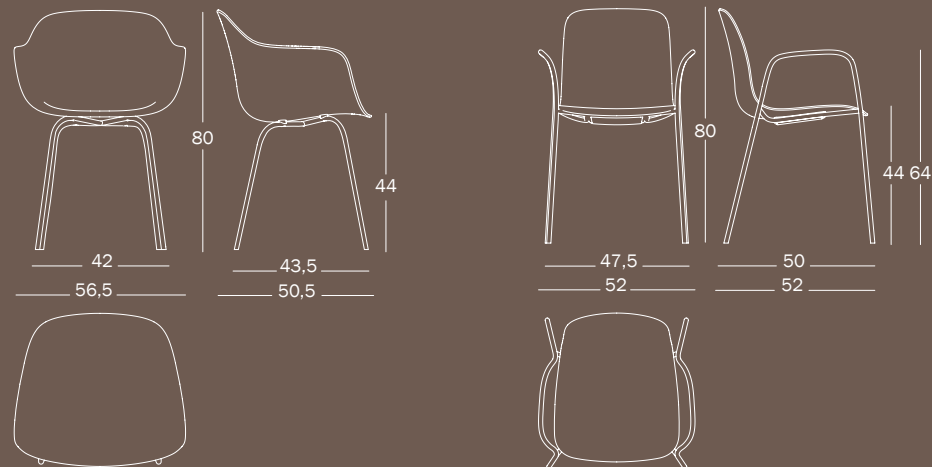

#### PRODUCT CARE

We recommend using a soft rag, either dry or wet. When needed, use ph-balanced liquid soap diluted in water. Do not use abrasive sponges, as they may leave scratches. Avoid using acidic products, solvents and products containing ammonia. Periodic maintenance and cleaning allows the product to keep its original look and lengthens the duration of its performance.

#### WARNING

Do not use different cleaning products from the ones mentioned above. Do not use the product in an improper way. Do not place hot objects on it, sit down on the back, stand on the seat or use the product as a ladder. Once disused, please make sure this product is disposed in an environment-friendly way. For the fabric version: treat stains immediately, the longer they remain in the fabric, the harder it is to remove them. Before choosing a cleaning method, always try it out on a concealed part of the chair.

Substance chair w/ frame in ash plywood



Frame in ash plywood /  
Colours

Seat in polypropylene /  
White, Black or Grey beige

Substance armchair w/ frame in ash plywood



Frame in ash plywood /  
Colours

Seat in polypropylene /  
Colours

Frame in ash plywood /



Natural 7018  
Black 7065

Polypropylene /



White 1735 C  
Black 1768 C  
Grey beige 1452 C  
Mustard 1015 C

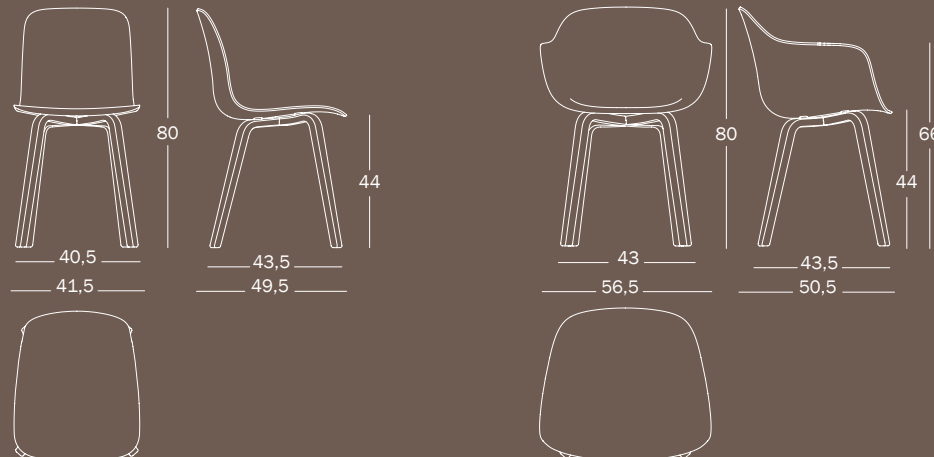

#### PRODUCT CARE

We recommend using a soft rag, either dry or wet. When needed, use ph-balanced liquid soap diluted in water. Do not use abrasive sponges, as they may leave scratches. Avoid using acidic products, solvents and products containing ammonia.

Periodic maintenance and cleaning allows the product to keep its original look and lengthens the duration of its performance.

#### WARNING

Do not use different cleaning products from the ones mentioned above. Do not use the product in an improper way. Do not place hot objects on it, sit down on the back, stand on the seat or use the product as a ladder. Once disused, please make sure this product is disposed in an environment-friendly way. For the fabric version: treat stains immediately, the longer they remain in the fabric, the harder it is to remove them. Before choosing a cleaning method, always try it out on a concealed part of the chair.



